

E-Flo® DC 4-Ball Piston Pumps

3A2096D
EN

Electric drive piston pumps for low to medium volume paint circulation applications.
For professional use only.



Important Safety Instructions

Read all warnings and instructions in this manual.
Save these instructions.

*See Technical Data, page 29, for
Maximum Working Pressure.
See page 3 for model part numbers and
approvals information.*

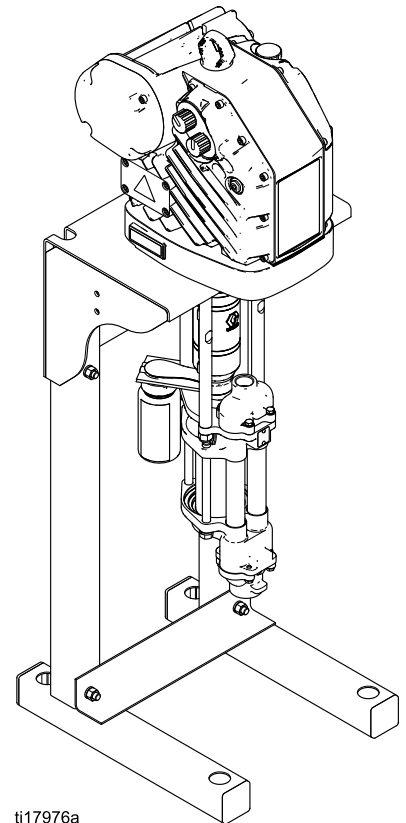

Contents

Models	3	Check Oil Level	14
Related Manuals	3	Bearing Pre-Load.....	14
Warnings	4	Flushing	14
Installation.....	8	Troubleshooting.....	15
Location	8	Repair.....	16
Mount the Pump	8	Disassembly	16
Power Supply Requirements.....	8	Reassembly	16
Connect the Power Supply	10	Reassemble the Coupling Adapter and Tie Rods to the Motor	17
Grounding	11	Parts.....	18
Fluid Line Accessories	12	Pump Assembly.....	18
Fill With Oil Before Using Equipment.....	12	Pump Matrix	20
Flush Before Using Equipment.....	12	Dimensions	22
Control Module Accessory	12	Mounting Hole Patterns.....	23
Operation.....	13	Performance Charts.....	25
Startup	13	Technical Data	29
Shutdown	13	Graco Standard Warranty.....	30
Pressure Relief Procedure.....	13		
Maintenance	14		
Preventive Maintenance Schedule	14		
Change the Oil.....	14		

Models

The part number for your equipment is printed on the equipment identification label (L). The part number includes digits from each of the following categories, depending on the configuration of your equipment. See [Pump Matrix, page 20](#) for a complete list of pump part numbers.

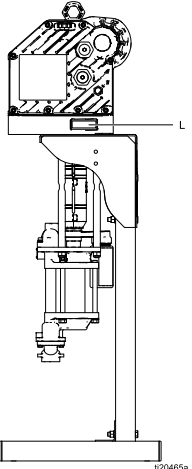
E-Flo DC Pump (EC)	Lower Pump Size (1, 2, 3, or 4)	Motor and Controls (1, 2, 3, or 4)	Pump Type and Fittings (1, 2, or 3)	Mounting Type (0, 1, or 2)	
EC	1 = 750 cc	1 = 1 Horsepower, Basic	1 = Hard Chrome, NPT	0 = None	
	2 = 1000 cc	2 = 1 Horsepower, Advanced	2 = Hard Chrome, Tri-Clamp	1 = Stand	
	3 = 1500 cc	3 = 2 Horsepower, Basic	3 = Maxlife, Tri-Clamp	2 = Wall Bracket	
	4 = 2000 cc	4 = 2 Horsepower, Advanced			

The following approvals apply to Basic models only (Part Nos. EC11xx, EC21xx, EC23xx, EC33xx, and EC43xx).







NOTE: See the E-Flo DC Motor manual for motor approvals information.





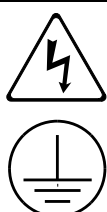

Related Manuals

Manual No.	Description
3A2526	Instructions-Parts Manual, E-Flo DC Motor
3A2527	Instructions-Parts Manual, for E-Flo DC Control Module Kit
332013	Instructions-Parts Manual, for Advanced Display Control Module (ADCM)
3A0539	Instructions-Parts Manual, 4-Ball Lowers

Warnings

The following warnings are for the setup, use, grounding, maintenance, and repair of this equipment. The exclamation point symbol alerts you to a general warning and the hazard symbols refer to procedure-specific risks. When these symbols appear in the body of this manual or on warning labels, refer back to these Warnings. Product-specific hazard symbols and warnings not covered in this section may appear throughout the body of this manual where applicable.

 <h2 style="margin: 0;">WARNING</h2>	
	<p>FIRE AND EXPLOSION HAZARD</p> <p>Flammable fumes, such as solvent and paint fumes, in work area can ignite or explode. To help prevent fire and explosion:</p> <ul style="list-style-type: none"> • Use equipment only in well ventilated area. • Eliminate all ignition sources; such as pilot lights, cigarettes, portable electric lamps, and plastic drop cloths (potential static arc). • Keep work area free of debris, including solvent, rags and gasoline. • Do not plug or unplug power cords, or turn power or light switches on or off when flammable fumes are present. • Ground all equipment in the work area. See Grounding instructions. • Use only grounded hoses. • Hold gun firmly to side of grounded pail when triggering into pail. Do not use pail liners unless they are antistatic or conductive. • Stop operation immediately if static sparking occurs or you feel a shock, Do not use equipment until you identify and correct the problem. • Keep a working fire extinguisher in the work area. <p>Static charge may build up on plastic parts during cleaning and could discharge and ignite flammable vapors. To help prevent fire and explosion:</p> <ul style="list-style-type: none"> • Clean plastic parts only in well ventilated area. • Do not clean with a dry cloth. • Do not operate electrostatic guns in equipment work area.
	<p>ELECTRIC SHOCK HAZARD</p> <p>This equipment must be grounded. Improper grounding, setup, or usage of the system can cause electric shock.</p> <ul style="list-style-type: none"> • Turn off and disconnect power at main switch before disconnecting any cables and before servicing or installing equipment. • Connect only to grounded power source. • All electrical wiring must be done by a qualified electrician and comply with all local codes and regulations.
	<p>BURN HAZARD</p> <p>Equipment surfaces and fluid that's heated can become very hot during operation. To avoid severe burns:</p> <ul style="list-style-type: none"> • Do not touch hot fluid or equipment.

 <h1 style="margin: 0;">WARNING</h1>	
 	<p>MOVING PARTS HAZARD Moving parts can pinch, cut or amputate fingers and other body parts.</p> <ul style="list-style-type: none"> • Keep clear of moving parts. • Do not operate equipment with protective guards or covers removed. • Pressurized equipment can start without warning. Before checking, moving, or servicing equipment, follow the Pressure Relief Procedure and disconnect all power sources.
 	<p>PRESSURIZED EQUIPMENT HAZARD Fluid from the equipment, leaks, or ruptured components can splash in the eyes or on skin and cause serious injury.</p> <ul style="list-style-type: none"> • Follow the Pressure Relief Procedure when you stop spraying/dispensing and before cleaning, checking, or servicing equipment. • Tighten all fluid connections before operating the equipment. • Check hoses, tubes, and couplings daily. Replace worn or damaged parts immediately.
	<p>TOXIC FLUID OR FUMES Toxic fluids or fumes can cause serious injury or death if splashed in the eyes or on skin, inhaled, or swallowed.</p> <ul style="list-style-type: none"> • Read MSDSs to know the specific hazards of the fluids you are using. • Store hazardous fluid in approved containers, and dispose of it according to applicable guidelines.
	<p>PERSONAL PROTECTIVE EQUIPMENT Wear appropriate protective equipment when in the work area to help prevent serious injury, including eye injury, hearing loss, inhalation of toxic fumes, and burns. This equipment includes but is not limited to:</p> <ul style="list-style-type: none"> • Protective eyewear, and hearing protection. • Respirators, protective clothing, and gloves as recommended by the fluid and solvent manufacturer.

WARNING







EQUIPMENT MISUSE HAZARD

Misuse can cause death or serious injury.

- Do not operate the unit when fatigued or under the influence of drugs or alcohol.
- Do not exceed the maximum working pressure or temperature rating of the lowest rated system component. See **Technical Data** in all equipment manuals.
- Use fluids and solvents that are compatible with equipment wetted parts. See **Technical Data** in all equipment manuals. Read fluid and solvent manufacturer's warnings. For complete information about your material, request MSDS from distributor or retailer.
- Do not leave the work area while equipment is energized or under pressure.
- Turn off all equipment and follow the **Pressure Relief Procedure** when equipment is not in use.
- Check equipment daily. Repair or replace worn or damaged parts immediately with genuine manufacturer's replacement parts only.
- Do not alter or modify equipment. Alterations or modifications may void agency approvals and create safety hazards.
- Make sure all equipment is rated and approved for the environment in which you are using it.
- Use equipment only for its intended purpose. Call your distributor for information.
- Route hoses and cables away from traffic areas, sharp edges, moving parts, and hot surfaces.
- Do not kink or over bend hoses or use hoses to pull equipment.
- Keep children and animals away from work area.
- Comply with all applicable safety regulations.

Installation

				
<p>Installation of this equipment involves potentially hazardous procedures. Only trained and qualified personnel who have read and who understand the information in this manual should install this equipment.</p>				

Location

When selecting the location for the equipment, keep the following in mind:

- There must be sufficient space on all sides of the equipment for installation, operator access, maintenance, and air circulation.
- Ensure that the mounting surface and mounting hardware are strong enough to support the weight of the equipment, fluid, hoses, and stress caused during operation.
- There must be a start/stop control (C) within easy reach of the equipment. See Fig. 1.



Mount the Pump

See [Mounting Hole Patterns, page 23](#).

Secure the stand to the floor with M19 (5/8 in.) bolts which engage at least 152 mm (6 in.) into the concrete floor to prevent the pump from tipping.

Level the pump as required, using shims.

Power Supply Requirements

				
<p>Improper wiring may cause electric shock or other serious injury if work is not performed properly. Have a qualified electrician perform any electrical work. Be sure your installation complies with all National, State and Local safety and fire codes.</p>				

See Table 1 for power supply requirements. The system requires a dedicated circuit protected with a circuit breaker.

Table 1 . Power Supply Specifications

Model	Voltage	Phase	Hz	Current
EM0011 EM0012	100–250 Vac	1	50/60	20 A
EM0021 EM0022	200–250 Vac	1	50/60	20 A

Hazardous Area Cabling and Conduit Requirements

Explosion Proof

All electrical wiring in the hazardous area must be encased in Class I, Division I, Group D approved explosion-proof conduit. Follow all National, State, and Local electric codes.

A conduit seal (D) is required within 18 in. (457 mm) of the motor for the US and Canada. See Fig. 3.

All cables must be rated at 70°C (158°F).

Flame Proof (ATEX)

Use appropriate conduit, connectors, and cable glands rated for ATEX II 2 G. Follow all National, State, and Local electric codes.

All cable glands and cables must be rated at 70°C (158°F).

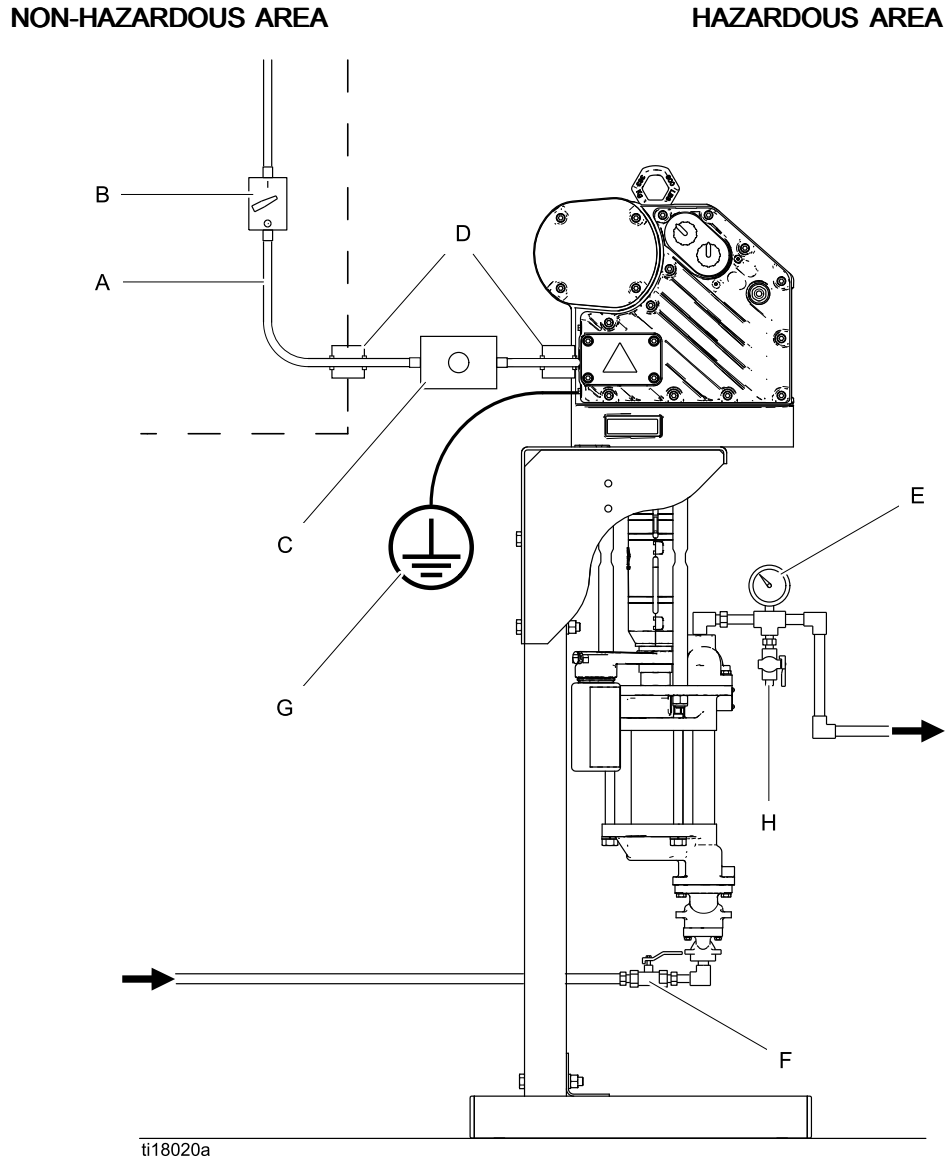

ti18020a

Figure 1 Typical Installation

Key for Fig. 1	
A	Electrical Supply (must be sealed conduit approved for use in hazardous locations)
B	Fused Safety Switch, with lock
C	Start/Stop Control (must be approved for use in hazardous locations)
D	Explosion Proof Conduit Seal. Required within 18 in. (457 mm) of the motor for the US and Canada.

Key for Fig. 1	
E	Fluid Pressure Gauge
F	Fluid Shutoff Valve
G	Pump Ground Wire. Two ground terminals are provided if local code requires redundant grounding connections.
H	Fluid Drain Valve

Connect the Power Supply

<p>Improper wiring may cause electric shock or other serious injury if work is not performed properly. Have a qualified electrician perform any electrical work. Be sure your installation complies with all National, State and Local safety and fire codes.</p>				

1. Ensure that the fused safety switch (B, Fig 2) is shut off and locked out.

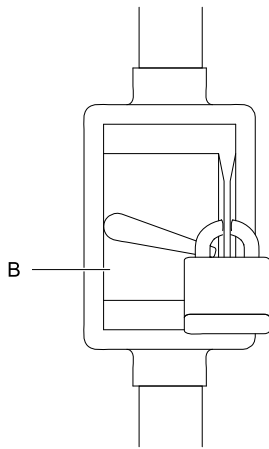

ti20170a

Figure 2 Locked Out Fused Safety Switch

2. See Fig. 3. Install a start/stop control (C) in the electrical supply line (A), within easy reach of the equipment. The start/stop control must be approved for use in hazardous locations.

3. Open the electrical compartment (S) on the motor.
4. Bring the power wires into the electrical compartment through the 3/4–14 npt(f) inlet port. Connect the wires to the terminals, as shown. Torque the terminal nuts to 25 in-lb (2.8 N•m) maximum. **Do not over-torque.**
5. Close the electrical compartment. Torque the cover screws to 15 ft-lb (20.3 N•m).

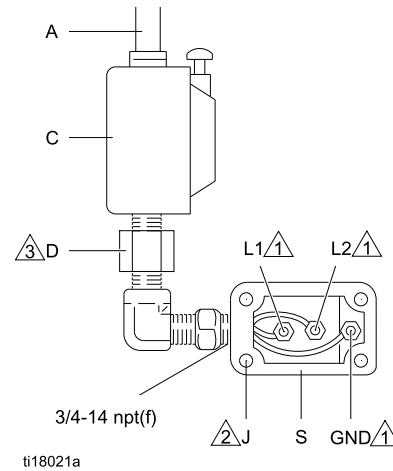





ti18021a

Figure 3 Connect the Power Wires

Notes for Fig. 3	
	Tighten all terminal nuts to 25 in-lb (2.8 N•m) maximum. Do not over-torque.
	Tighten cover screws to 15 ft-lb (20.3 N•m).
	A conduit seal (D) is required within 18 in. (457 mm) of the motor for the US and Canada.

Grounding

				
<p>This equipment must be grounded to reduce the risk of static sparking and electric shock. Electric or static sparking can cause fumes to ignite or explode. Improper grounding can cause electric shock. Grounding provides an escape wire for the electric current.</p>				

1. **Pump:** See Fig. 4. Loosen the ground screw and attach a ground wire. Tighten the ground screw securely. Connect the other end of the ground wire to a true earth ground.

NOTE: Advanced models require installation of the 24P822 Control Module. All pumps connected to a common control module must be grounded to the same ground point. Different ground points (unequal potential) may cause current to flow through component cables, causing incorrect signals.

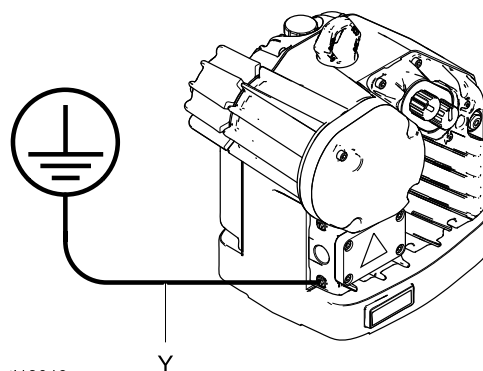

ti18019a

Figure 4 Ground Wire

2. **Fluid hoses:** Use only electrically conductive hoses with a maximum of 500 ft. (150 m) combined hose length to ensure grounding continuity. Check the electrical resistance of hoses. If total resistance to ground exceeds 25 megohms, replace hose immediately
3. **Fluid supply container:** Follow your local code.

Fluid Line Accessories

Install the following accessories in the order shown in Fig. 1, using adapters as necessary. All fluid lines and accessories must be rated to the maximum working pressure of 400 psi (2.8 MPa, 28.0 bar).

- **Fluid drain valve (D):** required in your system, to relieve fluid pressure in the hose and circulation system.
- **Fluid pressure gauge (E):** for more precise adjustment of the fluid pressure.
- **Fluid shutoff valve (F):** shuts off fluid flow.

Fill With Oil Before Using Equipment

See Fig. 5. Before using the equipment, open the fill cap (P) and add Graco Part No. 16W645 ISO 220 silicone-free synthetic gear oil. Check the oil level in the sight glass (K). Fill until the oil level is near the halfway point of the sight glass. The oil capacity is approximately 1.5 quarts (1.4 liters). **Do not overfill.**

NOTE: Two 1 quart (0.95 liter) bottles of oil are supplied with the equipment.

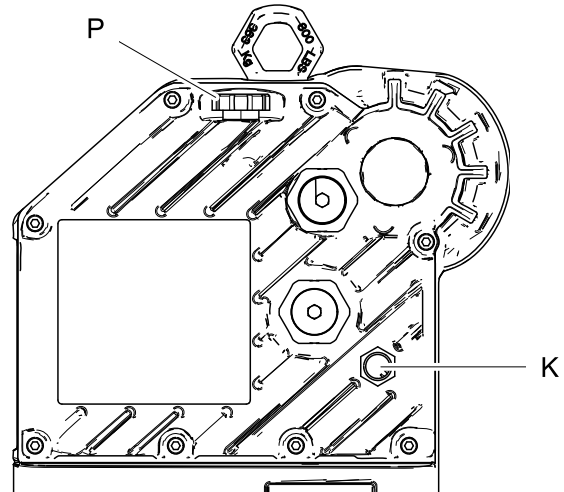

ti18022a

Figure 5 Sightglass and Oil Fill Cap

Flush Before Using Equipment

The pump fluid section was tested with lightweight oil, which is left in the fluid passages to protect parts. To avoid contaminating your fluid with oil, flush the equipment with a compatible solvent before using the equipment.

Control Module Accessory

The Control Module Accessory is required with Advanced E-Flo DC motors to provide the interface for users to enter selections and view information related to setup and operation. See the Control Module Accessory Kit manual for installation and operation information.

Operation

Startup



To operate the pump, follow the Startup instructions for the Basic or Advanced motor in the Motor manual. The Advanced E-Flo DC motors require installation of the 24P822 Control Module Accessory Kit to provide the interface for users to enter selections and view information related to setup and operation. See the Control Module Accessory Kit manual for installation and operation information.

Run the pump at a slow speed until the fluid lines are primed and all air is forced out of the system.

Shutdown

Follow the [Pressure Relief Procedure, page 13](#).

Pressure Relief Procedure

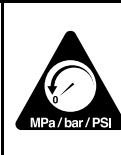
				
<p>This equipment stays pressurized until pressure is manually relieved. To help prevent serious injury from splashing fluid and moving parts, follow the Pressure Relief Procedure when you stop spraying and before cleaning, checking, or servicing the equipment.</p>				

1. Disengage the start/stop control (C). See Fig. 1.
2. Shut off and lock out the fused safety switch (B).
3. Open the fluid drain valve (D), having a waste container ready to catch drainage. Leave open until you are ready to pressurize system again.

Maintenance

Preventive Maintenance Schedule

The operating conditions of your particular system determine how often maintenance is required. Establish a preventive maintenance schedule by recording when and what kind of maintenance is needed, and then determine a regular schedule for checking your system.

Change the Oil

NOTE: Change the oil after a break-in period of 200,000–300,000 cycles. After the break-in period, change the oil once a year.

1. See Fig. 6. Place a minimum 2 quart (1.9 liter) container under the oil drain port. Remove the oil drain plug (25). Allow all oil to drain from the motor.
2. Reinstall the oil drain plug (25). Torque to 25–30 ft-lb (34–40 N•m).
3. See Fig. 7. Open the fill cap (P) and add Graco Part No. 16W645 ISO 220 silicone-free synthetic gear oil. Check the oil level in the sight glass (K). Fill until the oil level is near the halfway point of the sight glass. The oil capacity is approximately 1.5 quarts (1.4 liters). **Do not overfill.**
4. Reinstall the fill cap.

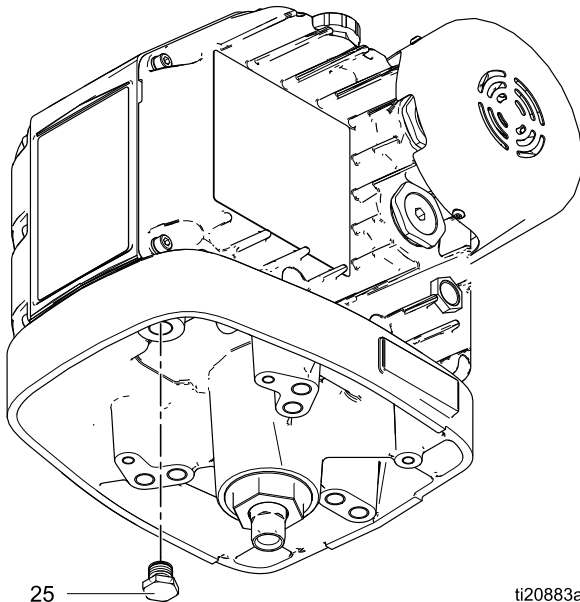

ti20883a

Figure 6 Oil Drain Plug

Check Oil Level

See Fig. 7. Check the oil level in the sight glass (K). The oil level should be near the halfway point of the sight glass when the unit is not running. If low, open the fill cap (P) and add Graco Part No. 16W645 ISO 220 silicone-free synthetic gear oil as required. The oil capacity is approximately 1.5 quarts (1.4 liters). **Do not overfill.**

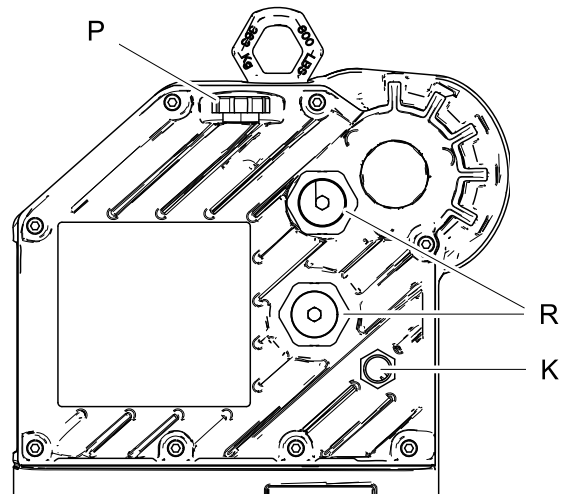

ti19679a

Figure 7 Sightglass and Oil Fill Cap

Bearing Pre-Load

See Fig. 7. The bearing pre-loads (R) are factory set and are not user adjustable. Do not adjust the bearing pre-loads.

Flushing

- Flush before changing fluids, before fluid can dry in the equipment, at the end of the day, before storing, and before repairing equipment.
- Flush at the lowest pressure possible. Check connectors for leaks and tighten as necessary.
- Flush with a fluid that is compatible with the fluid being dispensed and the equipment wetted parts.

Troubleshooting

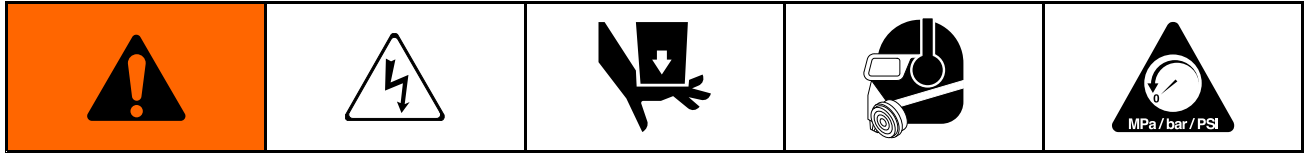

NOTE: Check all possible remedies before disassembling the pump.

NOTE: The LED on the motor will blink if an error is detected. See **Error Code Troubleshooting** in the motor manual for further information.

Problem	Cause	Solution
Pump output low on both strokes.	Inadequate power supply.	See Power Supply Requirements, page 8 .
	Exhausted fluid supply.	Refill and reprime pump.
	Clogged fluid outlet line, valves, etc.	Clear.
	Worn piston packing.	Replace. See lower manual.
Pump output low on only one stroke.	Held open or worn ball check valves.	Check and repair. See lower manual.
	Worn piston packing.	Replace. See lower manual.
No output.	Improperly installed ball check valves.	Check and repair. See lower manual.
Pump operates erratically.	Exhausted fluid supply.	Refill and reprime pump.
	Held open or worn ball check valves.	Check and repair. See lower manual.
	Worn piston packing.	Replace. See lower manual.
Pump will not operate.	Inadequate power supply.	See Power Supply Requirements, page 8 .
	Exhausted fluid supply.	Refill and reprime pump.
	Clogged fluid outlet line, valves, etc.	Clear.
	Fluid dried on piston rod.	Disassemble and clean pump. See lower manual. In future, stop pump at bottom of stroke.

Repair

Disassembly

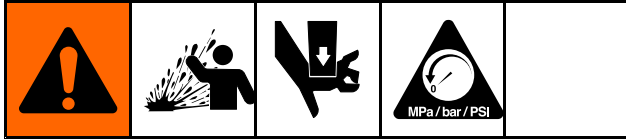

1. Stop the pump at the bottom of its stroke.
2. Relieve the pressure. See the [Pressure Relief Procedure, page 13](#).
3. Disconnect the hoses from the lower and plug the ends to prevent fluid contamination.
4. Remove the 2-piece shield (12) by inserting a screwdriver straight into the slot, and using it as a lever to release the tab. Repeat for all tabs. **Do not** use the screwdriver to pry the shields apart.

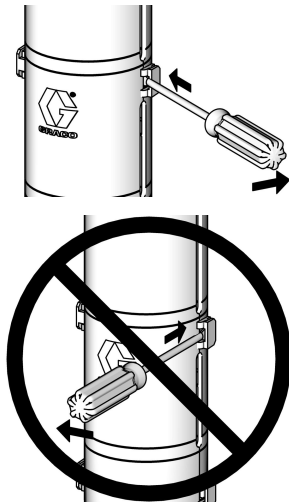

5. Loosen the coupling nut (11) and remove the collars (10). Remove the coupling nut from the piston rod (R). Unscrew the locknuts (8) from the tie rods (6). Separate the motor (3) and lower (7). See Fig. 7.
6. To repair the lower, see the lower manual.
7. There are no user-serviceable parts in the motor. Contact your Graco representative for assistance.

Reassembly

NOTE: If the coupling adapter (9) and tie rods (6) have been disassembled from the motor, see [Reassemble the Coupling Adapter and Tie Rods to the Motor, page 17](#).

1. See Fig. 8. Assemble the coupling nut (11) to the piston rod (R).
2. Orient the lower (7) to the motor (3). Position the lower on the tie rods (6). Lubricate the threads of the tie rods. Screw the tie rod locknuts (8) onto the tie rods. Tighten the locknuts and torque to 50-60 ft-lb (68-81 N•m).
3. Insert the collars (10) into the coupling nut (11). Tighten the coupling nut onto the coupling adapter (9) and torque to 90-100 ft-lb (122-135 N•m).
4. Install the shields (12) by engaging the bottom lips with the groove in the wet-cup cap. Snap the two shields together.

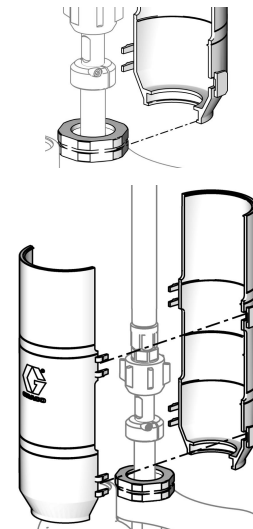

5. Flush and test the pump before reinstalling it in the system. Connect hoses and flush the pump. While it is pressurized, check for smooth operation and leaks. Adjust or repair as necessary before reinstalling in the system. Reconnect the pump ground wire before operating.

Reassemble the Coupling Adapter and Tie Rods to the Motor

NOTE: Use this procedure only if the coupling adapter (9) and tie rods (6) have been disassembled from the motor, to ensure proper alignment of the motor shaft to the piston rod (R).

1. See Fig. 7. Screw the tie rods (6) into the motor (3) and torque to 50-60 ft-lb (68-81 N•m).
2. Screw the coupling adapter (9) into the motor shaft and torque to 90-100 ft-lb (122-135 N•m).
3. Reassemble the pump to the motor, as explained in [Reassembly, page 16](#).

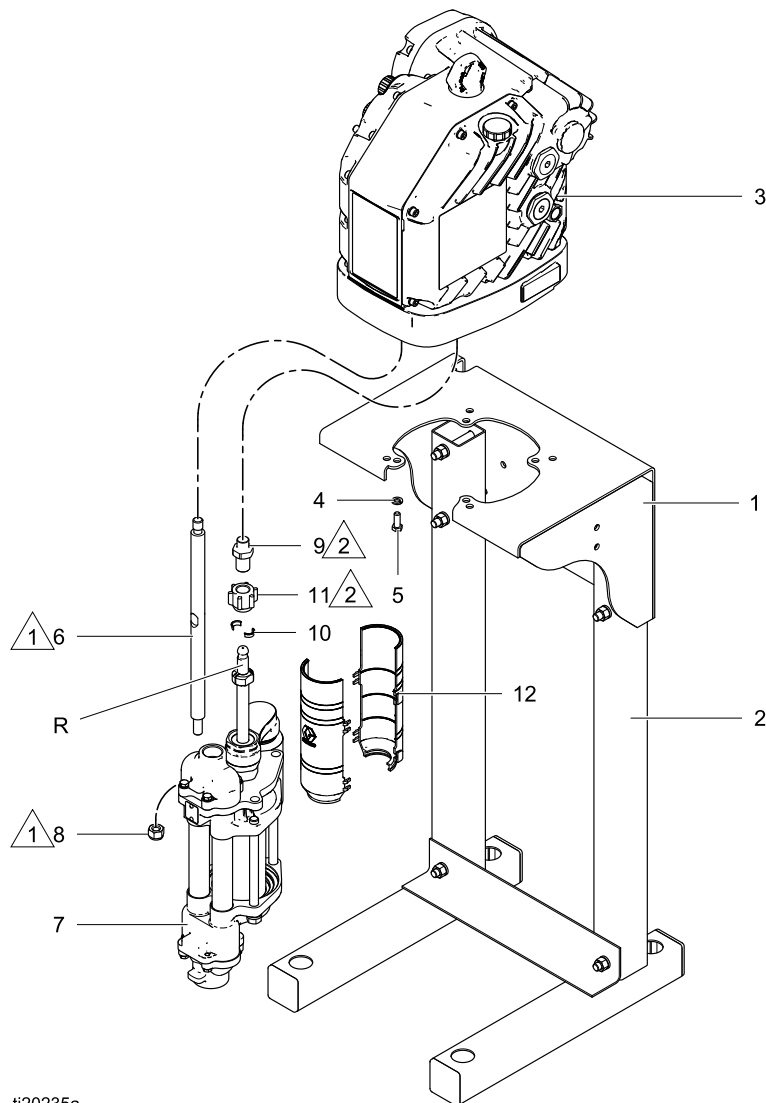

ti20235a

Figure 8 Pump Assembly

Notes for Fig. 8

1	Torque to 50-60 ft-lb (68-81 N•m).
2	Torque to 90-100 ft-lb (122-135 N•m).

Parts

Pump Assembly

See [Models](#), page 3 for an explanation of the pump part number.

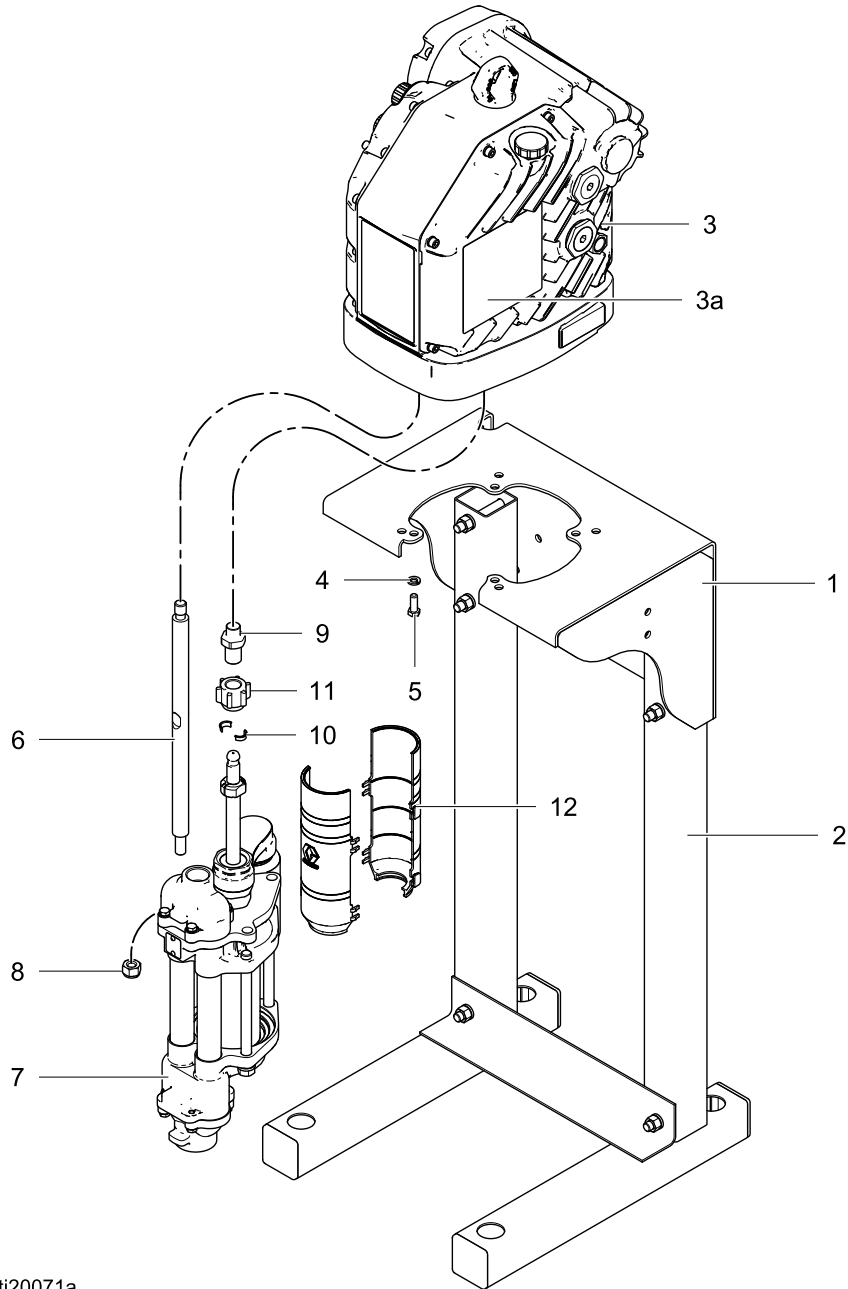

ti20071a

Ref	Part	Description	Qty
1	See Pump Matrix, page 20	KIT, mounting bracket, pump; includes items 4 and 5; see manual 311619	1
2	See Pump Matrix, page 20	STAND, floor	1
3	See Pump Matrix, page 20	MOTOR; Basic or Advanced; see motor manual; includes items 3a and 3b	1
3a [▲]	16M130	LABEL, warning	1
3b	16W645	OIL, gear, synthetic; ISO 220 silicone-free; 1 quart (0.95 liter); not shown	2
4	See Pump Matrix, page 20	WASHER	4
5	See Pump Matrix, page 20	BOLT	4
6	15G924	ROD, tie	3
7	See Pump Matrix, page 20	PUMP, displacement; see lower manual	1
8	108683	NUT, lock, hex	3
9	15H369	ADAPTER	1
10	184128	COLLAR, coupling	2
11	184059	NUT, coupling	1
12	24F251	KIT, shield, coupler (includes 2 pieces)	1

▲ Replacement Danger and Warning labels, tags, and cards are available at no cost.

Pump Matrix

Pump Part No.	Pump Series	Mounting Bracket (Ref 1)	Floor Stand (Ref 2)	Motor (Ref 3)	Washer (Ref 4)	Bolt (Ref 5)	Lower Pump (Ref 7)
EC1110	A			EM0011			24F413
EC1111	A	255143	256193	EM0011	100133	100101	24F413
EC1112	A	255143		EM0011	100133	100101	24F413
EC1210	A			EM0012			24F413
EC1211	A	255143	256193	EM0012	100133	100101	24F413
EC1212	A	255143		EM0012	100133	100101	24F413
EC2110	A			EM0011			24F424
EC2111	A	255143	256193	EM0011	100133	100101	24F424
EC2112	A	255143		EM0011	100133	100101	24F424
EC2210	A			EM0012			24F424
EC2211	A	255143	256193	EM0012	100133	100101	24F424
EC2212	A	255143		EM0012	100133	100101	24F424
EC2310	A			EM0021			24F424
EC2311	A	255143	256193	EM0021	100133	100101	24F424
EC2312	A	255143		EM0021	100133	100101	24F424
EC2410	A			EM0022			24F424
EC2411	A	255143	256193	EM0022	100133	100101	24F424
EC2412	A	255143		EM0022	100133	100101	24F424
EC2320	A			EM0021			24F426
EC2321	A	255143	256193	EM0021	100133	100101	24F426
EC2322	A	255143		EM0021	100133	100101	24F426
EC2420	A			EM0022			24F426
EC2421	A	255143	256193	EM0022	100133	100101	24F426
EC2422	A	255143		EM0022	100133	100101	24F426
EC2330	A			EM0021			24F427
EC2331	A	255143	256193	EM0021	100133	100101	24F427
EC2332	A	255143		EM0021	100133	100101	24F427
EC2430	A			EM0022			24F427
EC2431	A	255143	256193	EM0022	100133	100101	24F427
EC2432	A	255143		EM0022	100133	100101	24F427
EC3310	A			EM0021			24F432
EC3311	A	255143	256193	EM0021	100133	100101	24F432
EC3312	A	255143		EM0021	100133	100101	24F432

Pump Part No.	Pump Series	Mounting Bracket (Ref 1)	Floor Stand (Ref 2)	Motor (Ref 3)	Washer (Ref 4)	Bolt (Ref 5)	Lower Pump (Ref 7)
EC3410	A			EM0022			24F432
EC3411	A	255143	256193	EM0022	100133	100101	24F432
EC3412	A	255143		EM0022	100133	100101	24F432
EC3320	A			EM0021			24F434
EC3321	A	255143	256193	EM0021	100133	100101	24F434
EC3322	A	255143		EM0021	100133	100101	24F434
EC3420	A			EM0022			24F434
EC3421	A	255143	256193	EM0022	100133	100101	24F434
EC3422	A	255143		EM0022	100133	100101	24F434
EC3330	A			EM0021			24F435
EC3331	A	255143	256193	EM0021	100133	100101	24F435
EC3332	A	255143		EM0021	100133	100101	24F435
EC3430	A			EM0022			24F435
EC3431	A	255143	256193	EM0022	100133	100101	24F435
EC3432	A	255143		EM0022	100133	100101	24F435
EC4310	A			EM0021			24F440
EC4311	A	255143	256193	EM0021	100133	100101	24F440
EC4312	A	255143		EM0021	100133	100101	24F440
EC4410	A			EM0022			24F440
EC4411	A	255143	256193	EM0022	100133	100101	24F440
EC4412	A	255143		EM0022	100133	100101	24F440
EC4320	A			EM0021			24F441
EC4321	A	255143	256193	EM0021	100133	100101	24F441
EC4322	A	255143		EM0021	100133	100101	24F441
EC4420	A			EM0022			24F441
EC4421	A	255143	256193	EM0022	100133	100101	24F441
EC4422	A	255143		EM0022	100133	100101	24F441
EC4330	A			EM0021			24F442
EC4331	A	255143	256193	EM0021	100133	100101	24F442
EC4332	A	255143		EM0021	100133	100101	24F442
EC4430	A			EM0022			24F442
EC4431	A	255143	256193	EM0022	100133	100101	24F442
EC4432	A	255143		EM0022	100133	100101	24F442

Dimensions

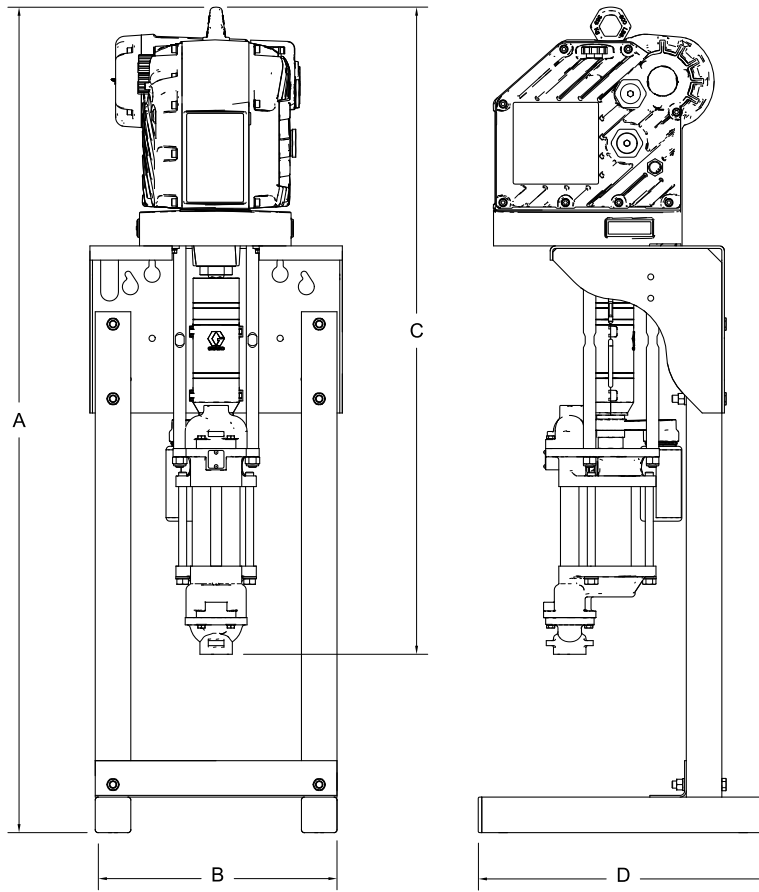

ti20465a

A	B	C	D
58.00 in. (1473 mm)	17.00 in. (432 mm)	45.50 in. (1156 mm)	19.88 in. (505 mm)

Mounting Hole Patterns

Floor Stand

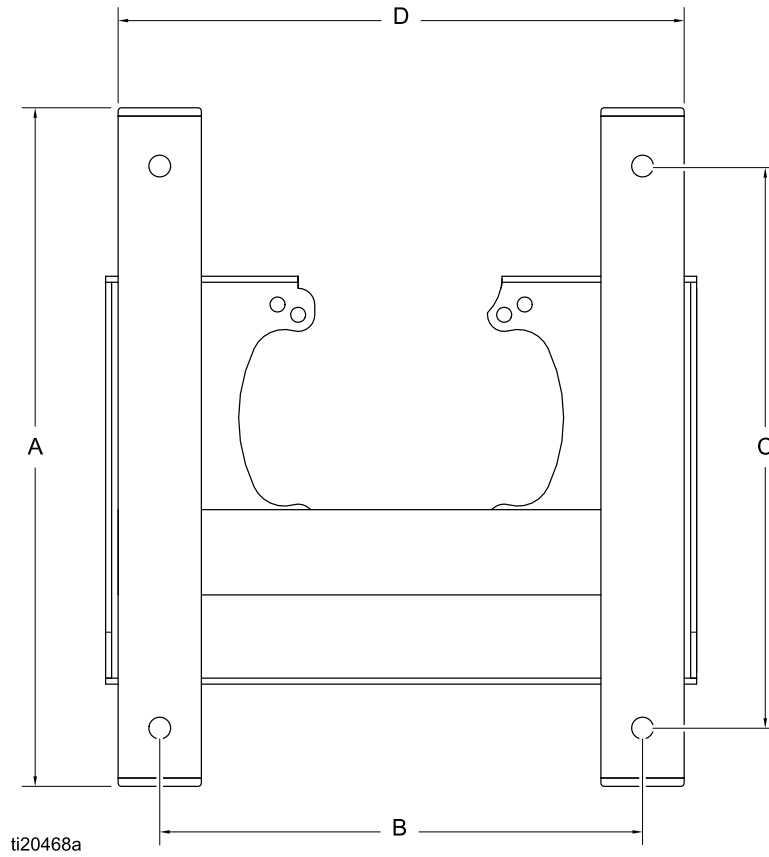

Dimension	Measurement
A	19.88 in. (505 mm)
B	14.50 in. (368 mm)
C	16.88 in. (429 mm)
D	17.00 in. (432 mm)

Mounting Hole Patterns

Pump Bracket

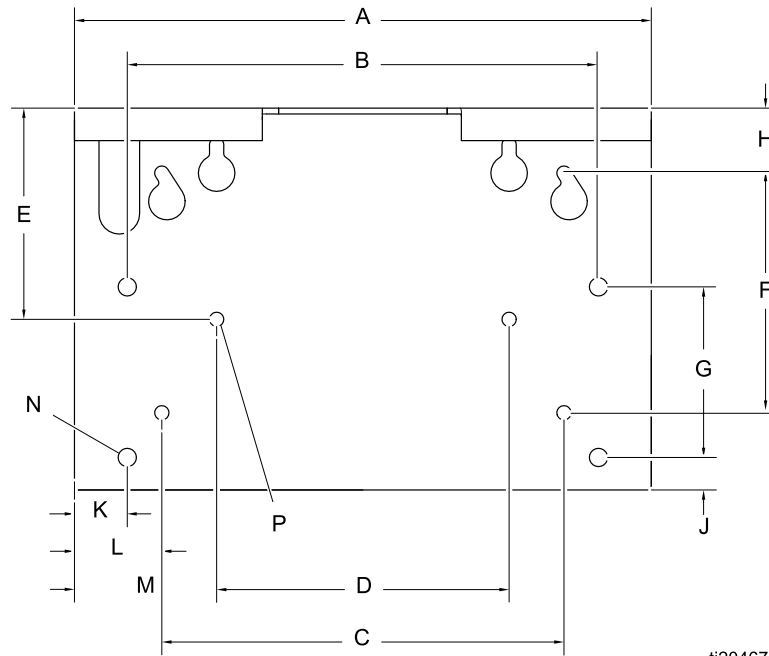

ti20467a

Dimension	Measurement
A	17.8 in. (451 mm)
B	14.5 in. (368 mm)
C	12.4 in. (314 mm)
D	9.0 in. (229 mm)
E	5.4 in. (137 mm)
F	7.4 in. (187 mm)
G	5.3 in. (133 mm)
H	2.0 in. (51 mm)
J	1.0 in. (25 mm)
K	1.6 in. (41 mm)
L	2.7 in. (69 mm)
M	4.4 in. (112 mm)
N	Four 0.562 in. (14 mm) diameter holes for mounting to stand
P	Four 0.438 in. (11 mm) diameter holes for mounting to wall

Performance Charts

To find the fluid pressure (psi/bar/MPa) at a specific fluid flow (gpm/lpm) and percentage of maximum force:

1. Locate the desired fluid flow in the scale at the bottom of the chart.
2. Follow the vertical line up to the intersection with the selected percentage of maximum force (see the **Key** below).
3. Follow left to the vertical scale to read the fluid outlet pressure.

Key to Performance Charts

NOTE: The charts show the motor operating at 100%, 70%, and 40% of maximum force. These values are approximately equivalent to an air motor operating at 100, 70, and 40 psi.

100% of maximum force	—————
70% of maximum force	- - - - -
40% of maximum force	- - - - -

Table 2 . Models EC11xx and EC12xx (750 cc lower, 1 HP motor, 1400 lb maximum force)

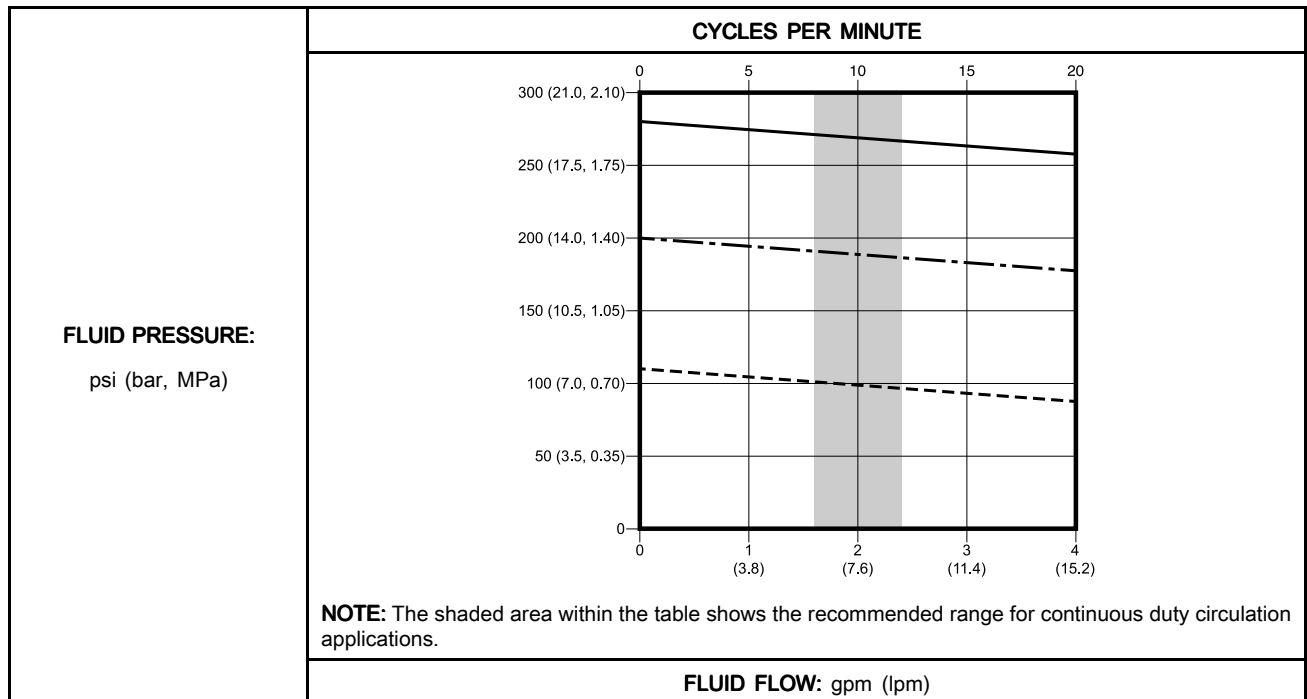

Table 3 . Models EC21xx and EC22xx (1000 cc lower, 1 HP motor, 1400 lb maximum force)

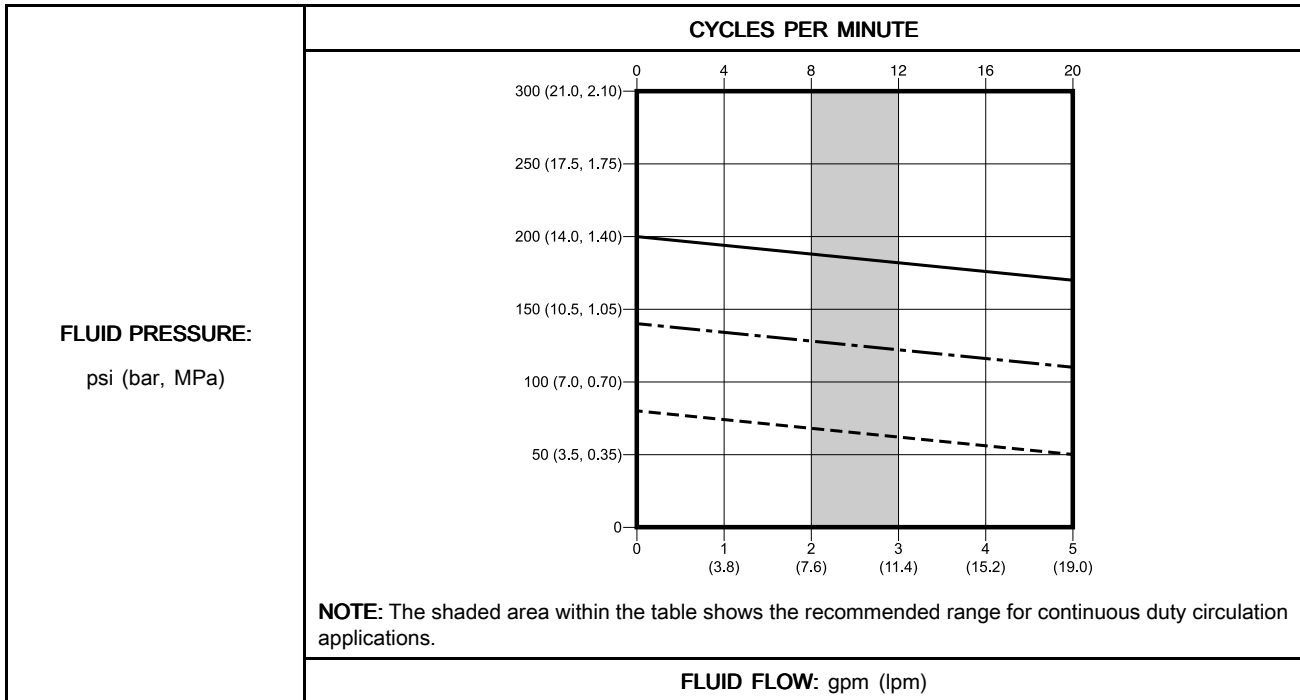

Table 4 . Models EC23xx and EC24xx (1000 cc lower, 2 HP motor, 2800 lb maximum force)

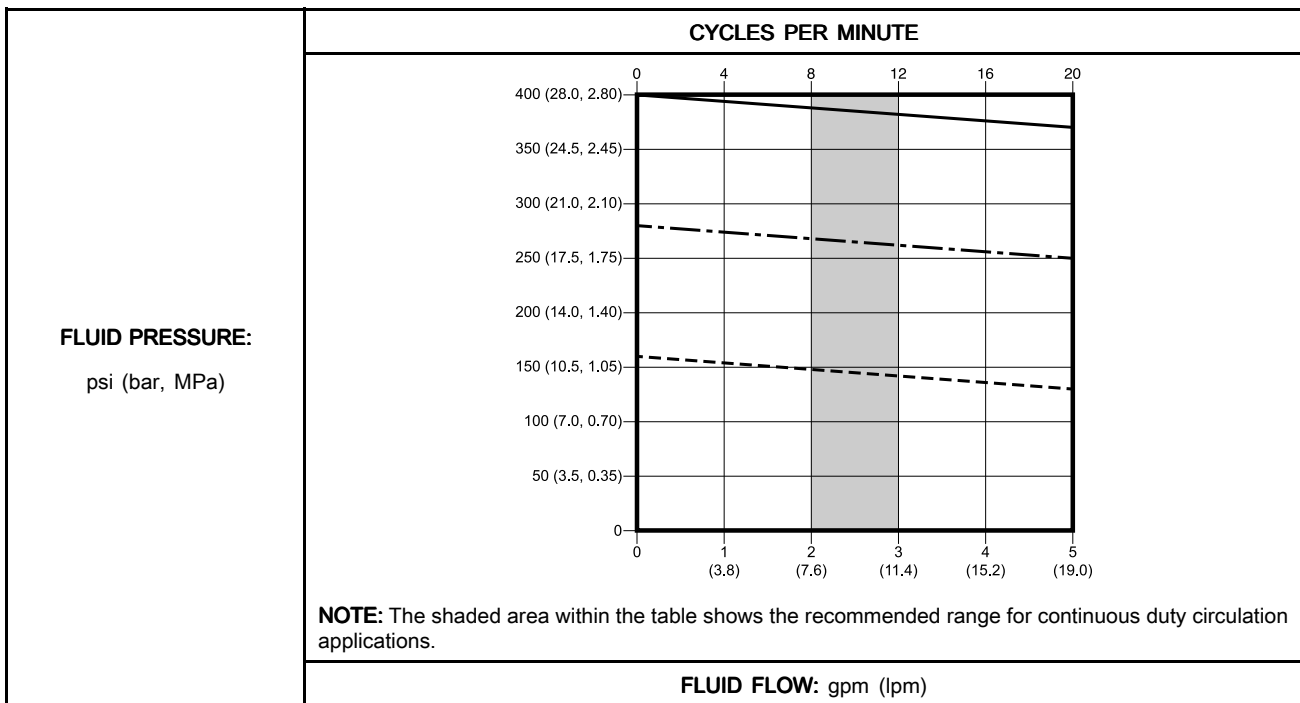

Table 5 . Models EC33xx and EC34xx (1500 cc lower, 2 HP motor, 2800 lb maximum force)

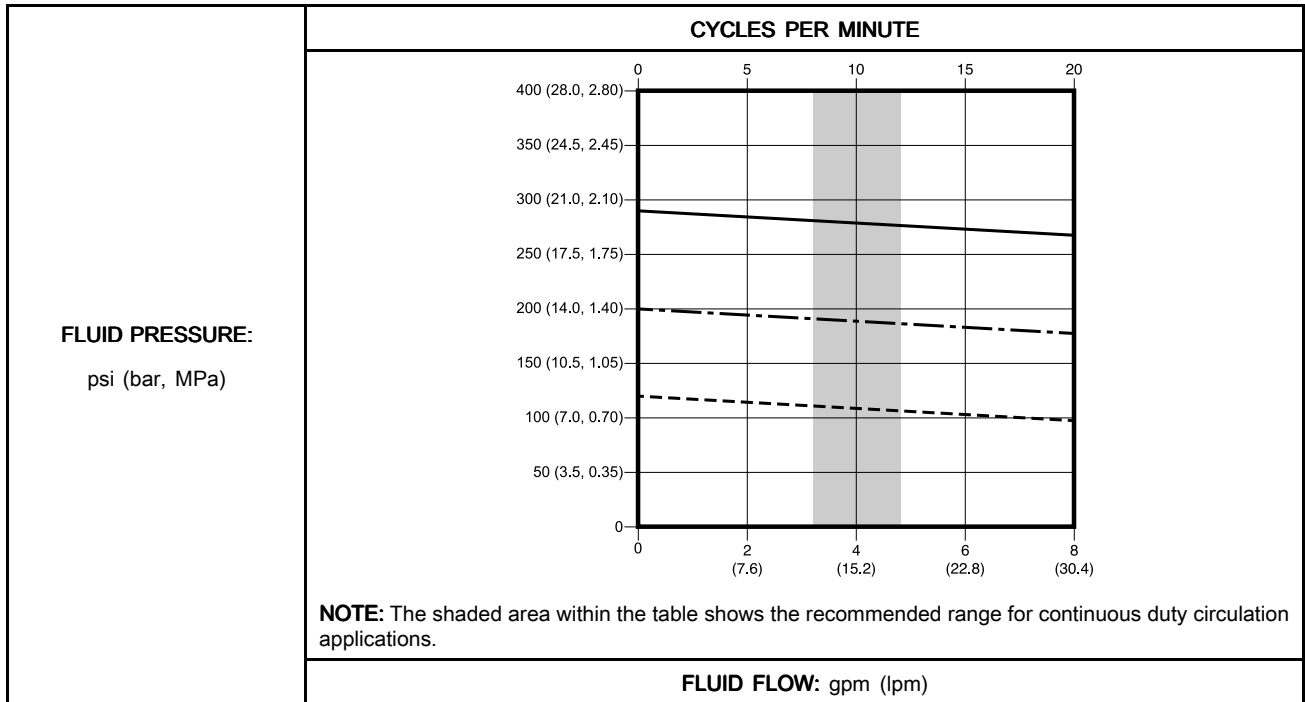
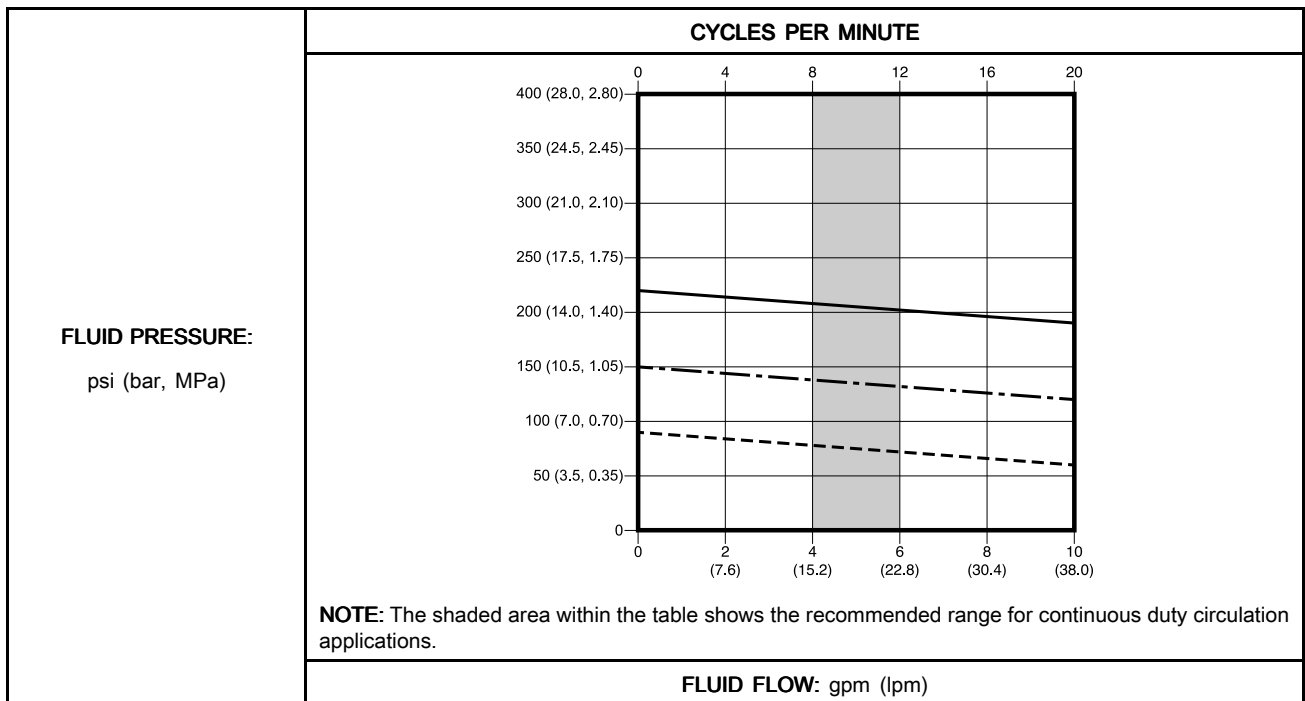

Table 6 . Models EC43xx and EC44xx (2000 cc lower, 2 HP motor, 2800 lb maximum force)



Notes

Notes

Technical Data

E-Flo DC Pumps	U.S.	Metric
Maximum fluid working pressure:		
Models EC11xx and EC12xx	300 psi	2.07 MPa, 20.7 bar
Models EC21xx and EC22xx	200 psi	1.38 MPa, 13.8 bar
Models EC23xx and EC24xx	400 psi	2.76 MPa, 27.6 bar
Models EC33xx and EC34xx	300 psi	2.07 MPa, 20.7 bar
Models EC43xx and EC44xx	220 psi	1.52 MPa, 15.2 bar
Maximum potential fluid pressure:		
Models ECx1xx and ECx2xx	218000/v (volume of lower in cc) = psi	1500/v (volume of lower in cc) = bar
Models ECx3xx and ECx4xx	436000/v (volume of lower in cc) = psi	3000/v (volume of lower in cc) = bar
Maximum continuous cycle rate	20 cpm	
Maximum Flow	Maximum flow is determined by the size of the pump lower. See Performance Charts, page 25 .	
Input voltage:		
Models ECx1xx and ECx2xx	100–250 Vac, single phase, 50/60 Hz	
Models ECx3xx and ECx4xx	200–250 Vac, single phase, 50/60 Hz	
Input current	20 A maximum	
Power inlet port size	3/4–14 npt(f)	
Ambient temperature range	32–104°F	0–40°C
Sound data	Less than 70 dB(A)	
Oil capacity	1.5 quarts	1.4 liters
Oil specification	Graco Part No. 16W645 ISO 220 silicone-free synthetic gear oil	
Weight	Pump package (motor, 1000cc lower, stand, and tie rods): 220 lb	Pump package (motor, 1000cc lower, stand, and tie rods): 99.8 kg
Fluid inlet size	1–1/2 npt(f)	
Fluid outlet size	1 npt(f)	
Wetted parts	See Lower Pump manual.	

Graco Standard Warranty

Graco warrants all equipment referenced in this document which is manufactured by Graco and bearing its name to be free from defects in material and workmanship on the date of sale to the original purchaser for use. With the exception of any special, extended, or limited warranty published by Graco, Graco will, for a period of twelve months from the date of sale, repair or replace any part of the equipment determined by Graco to be defective. This warranty applies only when the equipment is installed, operated and maintained in accordance with Graco's written recommendations.

This warranty does not cover, and Graco shall not be liable for general wear and tear, or any malfunction, damage or wear caused by faulty installation, misapplication, abrasion, corrosion, inadequate or improper maintenance, negligence, accident, tampering, or substitution of non-Graco component parts. Nor shall Graco be liable for malfunction, damage or wear caused by the incompatibility of Graco equipment with structures, accessories, equipment or materials not supplied by Graco, or the improper design, manufacture, installation, operation or maintenance of structures, accessories, equipment or materials not supplied by Graco.

This warranty is conditioned upon the prepaid return of the equipment claimed to be defective to an authorized Graco distributor for verification of the claimed defect. If the claimed defect is verified, Graco will repair or replace free of charge any defective parts. The equipment will be returned to the original purchaser transportation prepaid. If inspection of the equipment does not disclose any defect in material or workmanship, repairs will be made at a reasonable charge, which charges may include the costs of parts, labor, and transportation.

THIS WARRANTY IS EXCLUSIVE, AND IS IN LIEU OF ANY OTHER WARRANTIES, EXPRESS OR IMPLIED, INCLUDING BUT NOT LIMITED TO WARRANTY OF MERCHANTABILITY OR WARRANTY OF FITNESS FOR A PARTICULAR PURPOSE.

Graco's sole obligation and buyer's sole remedy for any breach of warranty shall be as set forth above. The buyer agrees that no other remedy (including, but not limited to, incidental or consequential damages for lost profits, lost sales, injury to person or property, or any other incidental or consequential loss) shall be available. Any action for breach of warranty must be brought within two (2) years of the date of sale.

GRACO MAKES NO WARRANTY, AND DISCLAIMS ALL IMPLIED WARRANTIES OF MERCHANTABILITY AND FITNESS FOR A PARTICULAR PURPOSE, IN CONNECTION WITH ACCESSORIES, EQUIPMENT, MATERIALS OR COMPONENTS SOLD BUT NOT MANUFACTURED BY GRACO. These items sold, but not manufactured by Graco (such as electric motors, switches, hose, etc.), are subject to the warranty, if any, of their manufacturer. Graco will provide purchaser with reasonable assistance in making any claim for breach of these warranties.

In no event will Graco be liable for indirect, incidental, special or consequential damages resulting from Graco supplying equipment hereunder, or the furnishing, performance, or use of any products or other goods sold hereto, whether due to a breach of contract, breach of warranty, the negligence of Graco, or otherwise.

FOR GRACO CANADA CUSTOMERS

The Parties acknowledge that they have required that the present document, as well as all documents, notices and legal proceedings entered into, given or instituted pursuant hereto or relating directly or indirectly hereto, be drawn up in English. Les parties reconnaissent avoir convenu que la rédaction du présente document sera en Anglais, ainsi que tous documents, avis et procédures judiciaires exécutés, donnés ou intentés, à la suite de ou en rapport, directement ou indirectement, avec les procédures concernées.

Graco Information

For the latest information about Graco products, visit www.graco.com. For patent information, see www.graco.com/patents.

To place an order, contact your Graco Distributor or call to identify the nearest distributor.

Phone: 612-623-6921 **or Toll Free:** 1-800-328-0211 **Fax:** 612-378-3505

All written and visual data contained in this document reflects the latest product information available at the time of publication. Graco reserves the right to make changes at any time without notice.

Original Instructions. This manual contains English, MM 3A2096

Graco Headquarters: Minneapolis

International Offices: Belgium, China, Japan, Korea

GRACO INC. AND SUBSIDIARIES • P.O. BOX 1441 • MINNEAPOLIS, MN 55440-1441 • USA
Copyright 2012, Graco Inc. All Graco manufacturing locations are registered to ISO 9001.

www.graco.com
Revised September 2014